

RELEASE

DATE:

COMPANY:

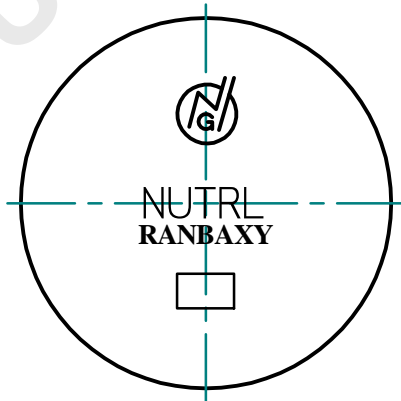
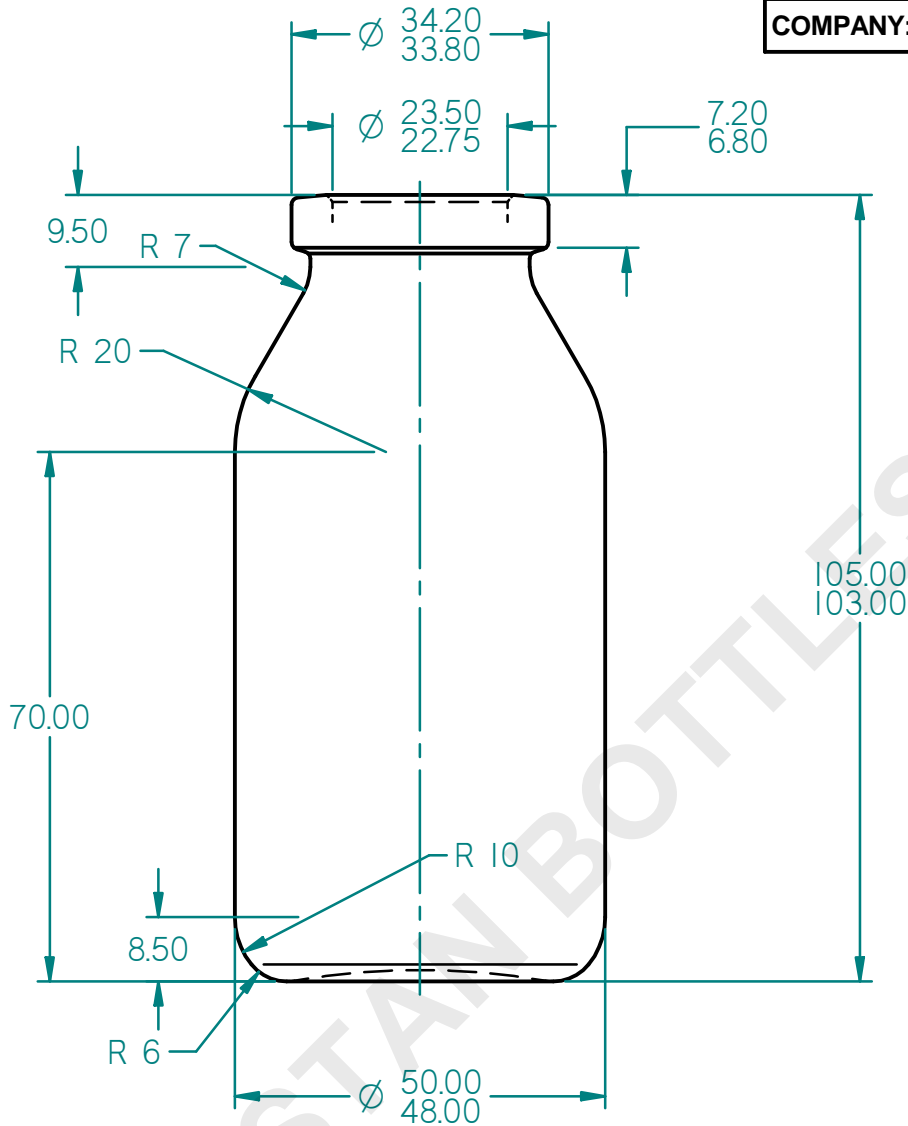

Protective note ISO 16016 observed

<b>GENERAL TOLERANCES</b> <b>DIN 6129-1</b> (DIMENSIONS WITHOUT TOLERANCES ARE FOR REFERENCE ONLY)				FINISH: 3/4 mm DIN		O'FLOW CAPACITY: 120.0 - 130.0 ml		ARTICLE NO.:  5155050100			
				FINISH DWG: NA		WEIGHT: 98 g Approx					
				FINISH MOLD NO: 139		TYPE OF GLASS: I COLOUR: FLINT					
				DATE		NAME		TITLE:  <b>100 mL RANBAXY</b>			
				DRAWN 21/11/2013		Paresh					
				CHECKED 21/11/2013		H.B.P.					
				SCALE 1:1							
				<b>GERRESHEIMER</b> NEUTRAL GLASS & ALLIED INDS. PVT. LTD. MUMBAI / KOSAMBA		MOLD NO.: 138		DRAWING NO.: B 5050		REVISION 0	
								SHEET 1 OF 1		FORMAT A4	
REV.				CHANGE		DATE		NAME		FILE: 100 mL RANBAXY.dft	